

### Product Summary

$V_{DS}$	40V
$R_{DS(on)@10V}$	< 5.5m $\Omega$
$I_D$	60A

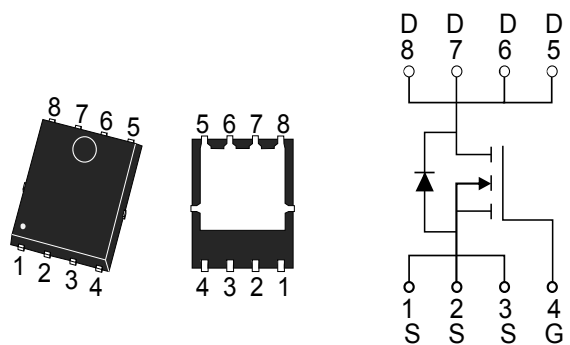

### PDFN5060-8L



### Applications

- Power switching application
- Uninterruptible power supply
- DC-DC convertor

### ■ Absolute Maximum Ratings ( $T_A=25^\circ\text{C}$ unless otherwise noted)

Parameter	Symbol	Limit	Unit
Drain-source Voltage	$V_{DS}$	40	V
Gate-source Voltage	$V_{GS}$	$\pm 20$	V
Drain Current	$I_D$	$T_C=25^\circ\text{C}$	60
		$T_C=70^\circ\text{C}$	39
Pulsed Drain Current <sup>A</sup>	$I_{DM}$	240	A
Avalanche energy <sup>B</sup>	EAS	85	mJ
Total Power Dissipation <sup>C</sup>	$P_D$	$T_C=25^\circ\text{C}$	40
		$T_C=70^\circ\text{C}$	30
Junction and Storage Temperature Range	$T_J, T_{STG}$	-55~+150	$^\circ\text{C}$



■ **Electrical Characteristics** ( $T_J=25^\circ\text{C}$  unless otherwise noted)

Parameter	Symbol	Conditions	Min	Typ	Max	Units
<b>Static Parameter</b>						
Drain-Source Breakdown Voltage	$BV_{DSS}$	$V_{GS}=0V, I_D=250\mu A$	40	-	-	V
		$V_{GS}=0V, I_D=1mA$	40	-	-	V
Zero Gate Voltage Drain Current	$I_{DSS}$	$V_{DS}=40V, V_{GS}=0V$	-	-	1	$\mu A$
		$V_{DS}=40V, V_{GS}=0V, T_J=150^\circ C$	-	-	100	
Gate-Body Leakage Current	$I_{GSS}$	$V_{GS}=\pm 20V, V_{DS}=0V$	-	-	$\pm 100$	nA
Gate Threshold Voltage	$V_{GS(th)}$	$V_{DS}=V_{GS}, I_D=250\mu A$	1.0	1.55	2.5	V
Static Drain-Source On-Resistance	$R_{DS(on)}$	$V_{GS}=10V, I_D=10A$	-	4.5	5.5	m $\Omega$
		$V_{GS}=4.5V, I_D=8A$	-	6.8	8.5	
Diode Forward Voltage	$V_{SD}$	$I_S=1A, V_{GS}=0V$	-	-	1.2	V
Gate resistance	$R_G$	$f=1MHz$	-	3.5	-	$\Omega$
Maximum Body-Diode Continuous Current	$I_S$		-	-	36	A
<b>Dynamic Parameters</b>						
Input Capacitance	$C_{iss}$	$V_{DS}=20V, V_{GS}=0V, f=1MHz$	600	948	1200	$\mu F$
Output Capacitance	$C_{oss}$		300	555	800	
Reverse Transfer Capacitance	$C_{rss}$		2	31	70	
<b>Switching Parameters</b>						
Total Gate Charge	$Q_g$	$V_{GS}=10V, V_{DS}=20V, I_D=50A$	10	17	30	nC
Gate-Source Charge	$Q_{gs}$		1	4.5	10	
Gate-Drain Charge	$Q_{gd}$		0.5	2	10	
Reverse Recovery Charge	$Q_{rr}$	$I_F=50A, di/dt=100A/\mu s$	-	22	-	nC
Reverse Recovery Time	$t_{rr}$		-	40	-	ns
Turn-on Delay Time	$t_{D(on)}$	$V_{GS}=10V, V_{DD}=20V, I_D=50A$ $R_{GEN}=3\Omega$	-	6.5	-	ns
Turn-on Rise Time	$t_r$		-	2.7	-	
Turn-off Delay Time	$t_{D(off)}$		-	26	-	
Turn-off fall Time	$t_f$		-	3.6	-	

A. Repetitive rating; pulse width limited by max. junction temperature.

B.  $T_J=25^\circ C, V_G=10V, R_G=25\Omega, L=0.5mH$

C.  $P_d$  is based on max. junction temperature, using junction-case and junction-ambient thermal resistance.



### Typical Electrical and Thermal Characteristics Diagrams

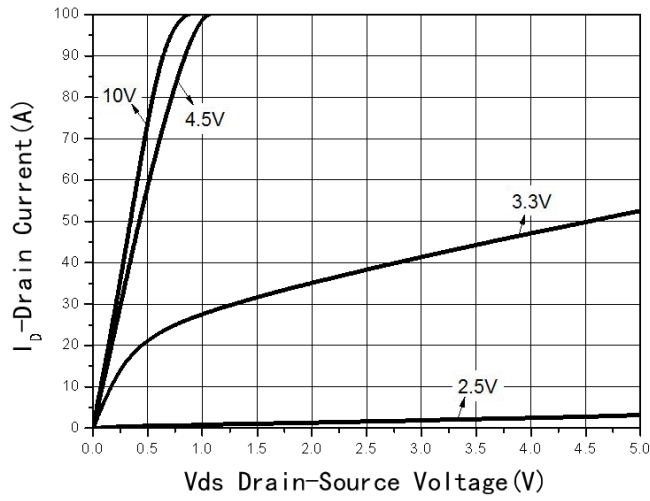

Fig1 Output Characteristics

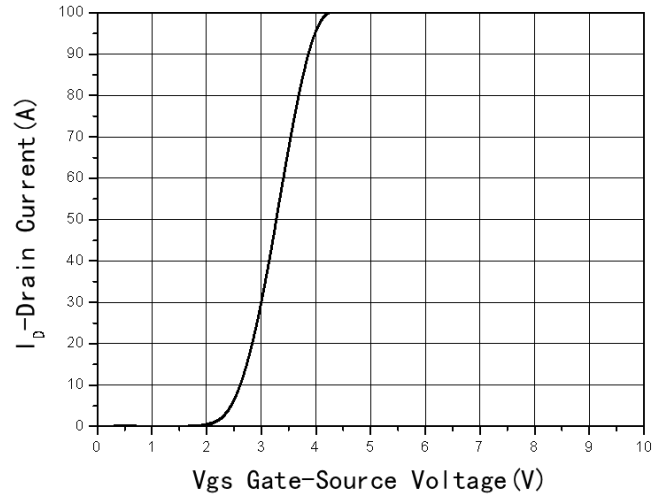

Fig2 Transfer Characteristics

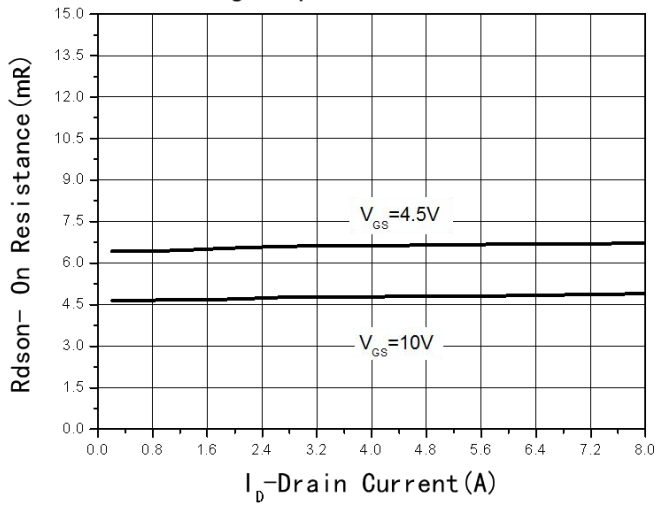

Fig3 Rdson-Drain current

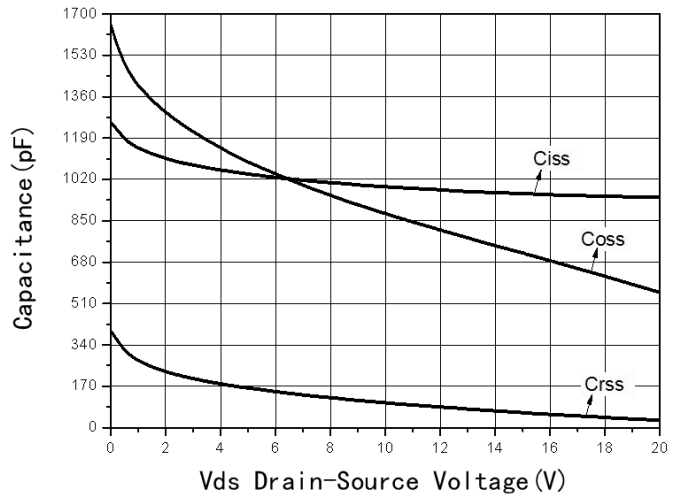

Fig4 Capacitance vs Vds

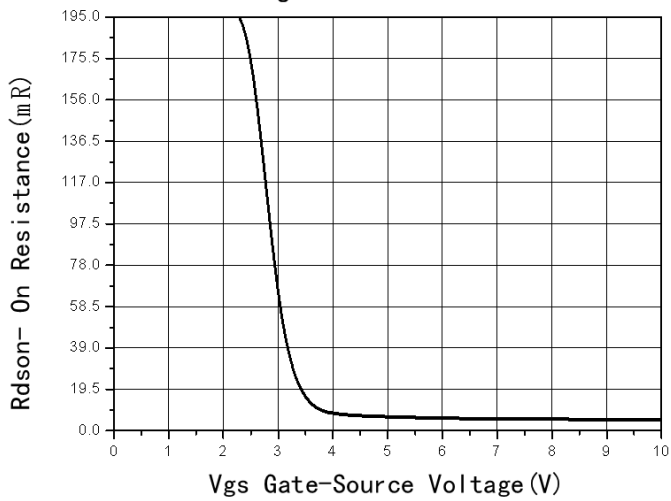

Fig5 Rdson-Gate Drain voltage

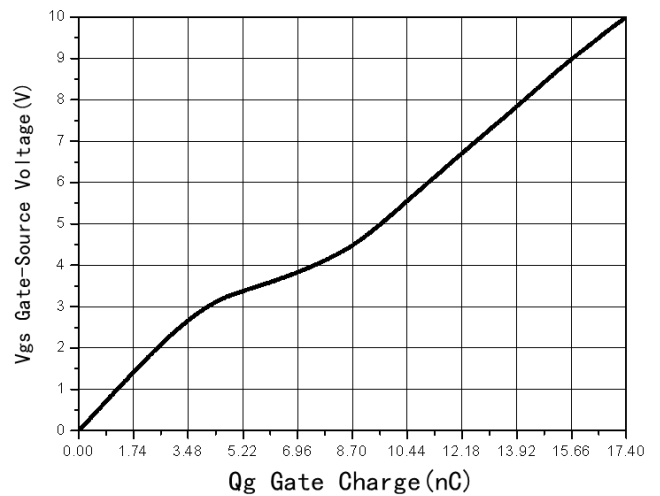

Fig6 Gate Charge



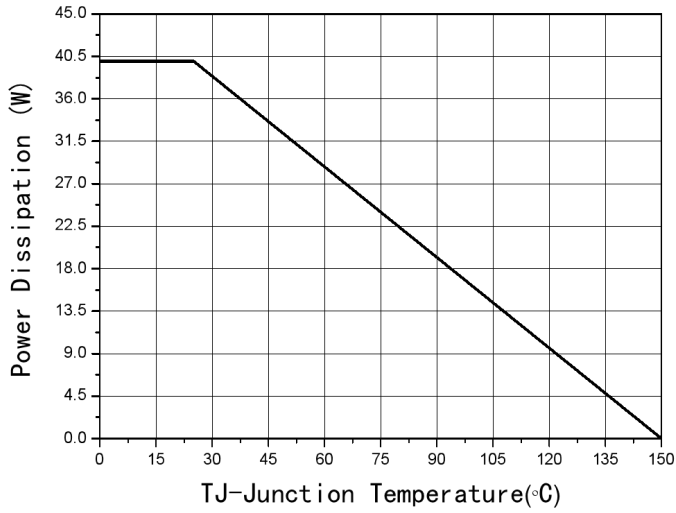

Fig7 Power De-rating

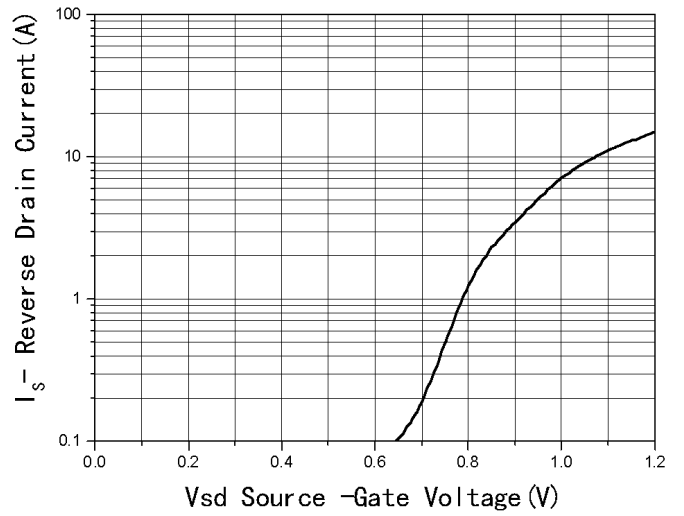
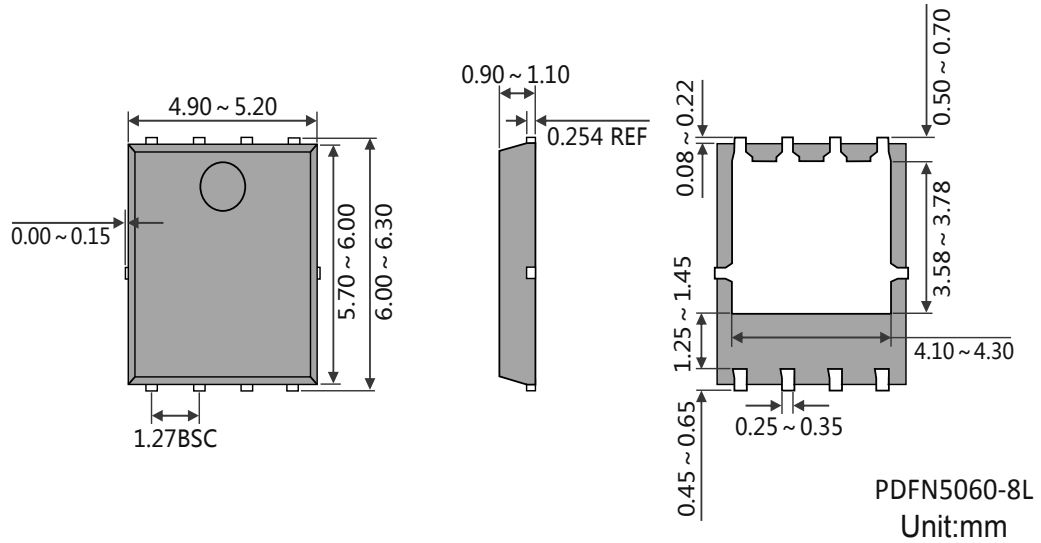

Fig8 Source-Drain Diode Forward



### Package Outline Dimensions



### Suggested Solder Pad Layout

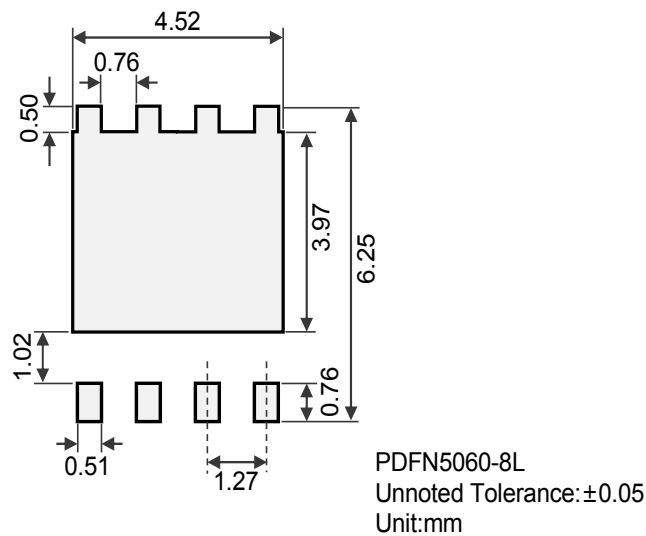

### Marking Information



“MHCHXM” = Product Logo  
 “Marking Code” = The Following  
 “XXXX” = Date Code Marking

Marking Code	Part Number
S40N55LNA	HXMS40N55LNA



### The Orientation Of The Product In The Carrier Tape

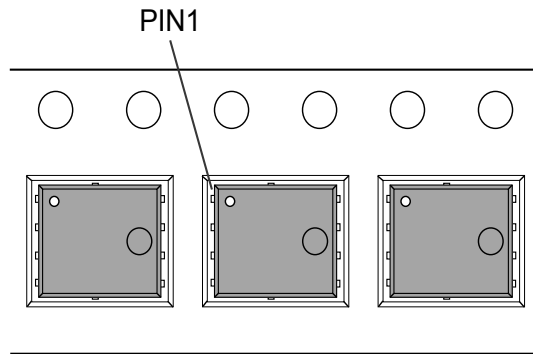

### Packing Information

Packaging	Part Number	Quantity(pcs)	Size(mm)
Reel	Reel	5000	$\Phi 330 \times \text{THK}15$
	Inner Box	10000	L355×W335×H48
	Outer Box	80000	L415×W375×H360

Packaging:Reel

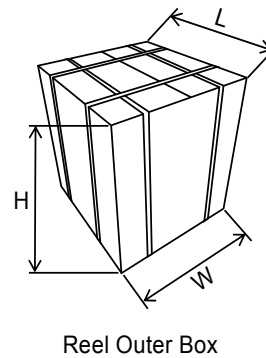
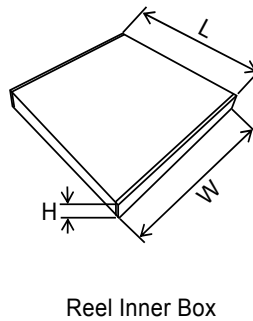
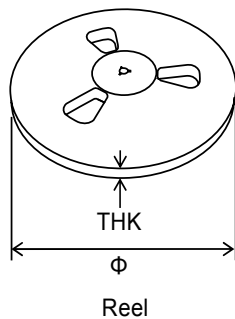

**DISCLAIMER**

1. Above specification may be changed without notice. MHCHXM will reserve authority on material change for above specification.
2. The graphs shown in this datasheet are representing typical data only and do not show guaranteed values.
3. When using this product, please observe the absolute maximum ratings and the instructions for use outlined in these specification sheets. MHCHXM assumes no responsibility for any damage resulting from use of the product which does not comply with the absolute maximum ratings and the instructions included in these specification sheets.
4. These specification sheets include materials protected under copyright of MHCHXM. Reproduction in any form is prohibited without the specific consent of MHCHXM.
5. This product is not intended to be used for military, aircraft, automotive, medical, life sustaining or life saving applications or any other application which can result in human injury or death. Please contact authorized MHCHXM sales agent for special application request.
6. Statements regarding the suitability of products for certain types of applications are based on MHCHXM's knowledge of typical requirements that are often placed on MHCHXM products in generic applications. Such statements are not binding statements about the suitability of products for a particular application. It is the customer's responsibility to validate that a particular product with the properties described in the product specification is suitable for use in a particular application. Parameters provided in datasheets and/or specifications may vary in different applications and performance may vary over time. All operating parameters, including typical parameters, must be validated for each customer application by the customer's technical experts. Product specifications do not expand or otherwise modify MHCHXM's terms and conditions of purchase, including but not limited to the warranty expressed therein.
7. This publication supersedes & replaces all information previously supplied. For additional application information, please visit our website <http://www.jshxm.com> , or consult your nearest MHCHXM's sales office for further assistance.

